

ARDUINO DUE

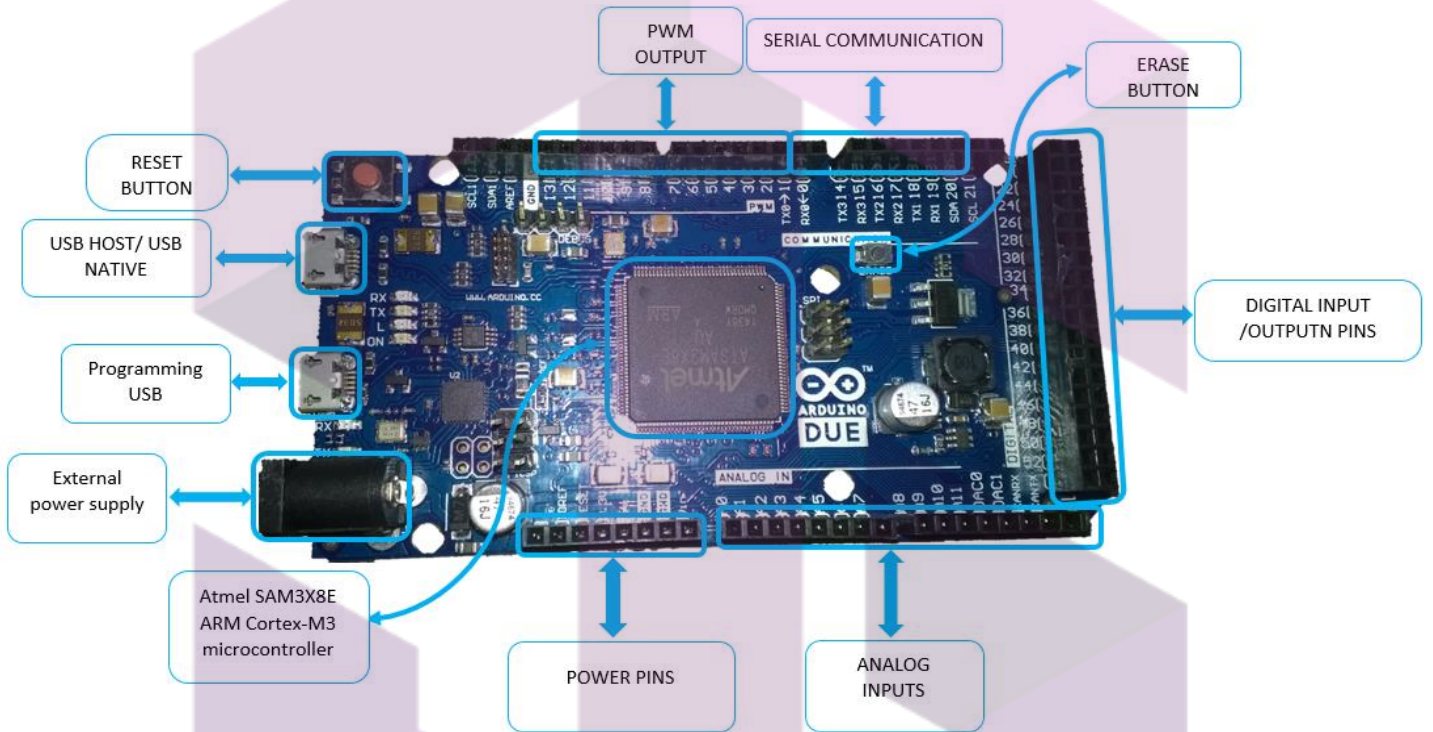

INTRODUCTION

The Arduino Due is the first Arduino board based on a 32-bit ARM core microcontroller. It is suitable for large scale projects and it differs from other Arduino kits as it runs at 3.3V as the maximum voltage.

ARDUINO DUE PHYSICAL COMPONENTS

It is based on **Atmel SAM3X8E ARM Cortex-M3** microcontroller, which is a member of a family of Flash microcontrollers based on the high performance 32-bit ARM Cortex-M3 RISC processor. It operates at a maximum speed of 84 MHz and up to 512 Kbytes of Flash memory and up to 100 Kbytes of SRAM. And its features are as follows:

- Core
 - ARM Cortex-M3 revision 2.0 running at up to 84 MHz
 - Memory Protection Unit (MPU)
 - 24-bit SysTick Counter
 - Nested Vector Interrupt Controller

- Memories
 - 256 to 512 Kbytes embedded Flash, 128-bit wide access, memory accelerator, dual bank
 - 32 to 100 Kbytes embedded SRAM with dual banks
 - 16 Kbytes ROM with embedded bootloader routines (UART, USB) and IAP routines
 - Static Memory Controller (SMC): SRAM, NOR, NAND support. NFC with 4 Kbyte RAM buffer and ECC
- System
 - Embedded voltage regulator for single supply operation
 - Power-on-Reset (POR), Brown-out Detector (BOD) and Watchdog for safe reset
 - Quartz or ceramic resonator oscillators: 3 to 20 MHz main and optional low power 32.768 kHz for RTC or device clock
 - High precision 8/12 MHz factory trimmed internal RC oscillator with 4 MHz default frequency for fast device
- startup
 - Slow Clock Internal RC oscillator as permanent clock for device clock in low-power mode
 - One PLL for device clock and one dedicated PLL for USB 2.0 High Speed Mini Host/Device
 - Temperature Sensor
 - Up to 17 peripheral DMA (PDC) channels and 6-channel central DMA plus dedicated DMA for High-Speed USB
 - Mini Host/Device and Ethernet MAC
- Low-power Modes
 - Sleep, Wait and Backup modes, down to 2.5 μ A in Backup mode with RTC, RTT, and GPBR

ARDUINO DUE FEATURES

Microcontroller	AT91SAM3X8E
Operating Voltage	3.3V
Input Voltage (recommended)	7-12V
Input Voltage (limits)	6-16V
Digital I/O Pins	54 (of which 12 provide PWM output)
Analog Input Pins	12
Analog Output Pins	2 (DAC)

Total DC Output Current on all I/O lines	130 mA
DC Current for 3.3V Pin	800 mA
DC Current for 5V Pin	800 mA
Flash Memory	512 KB all available for the user applications
SRAM	96 KB (two banks: 64KB and 32KB)
Clock Speed	84 MHz
Length	101.52 mm
Width	53.3 mm
Weight	36 g

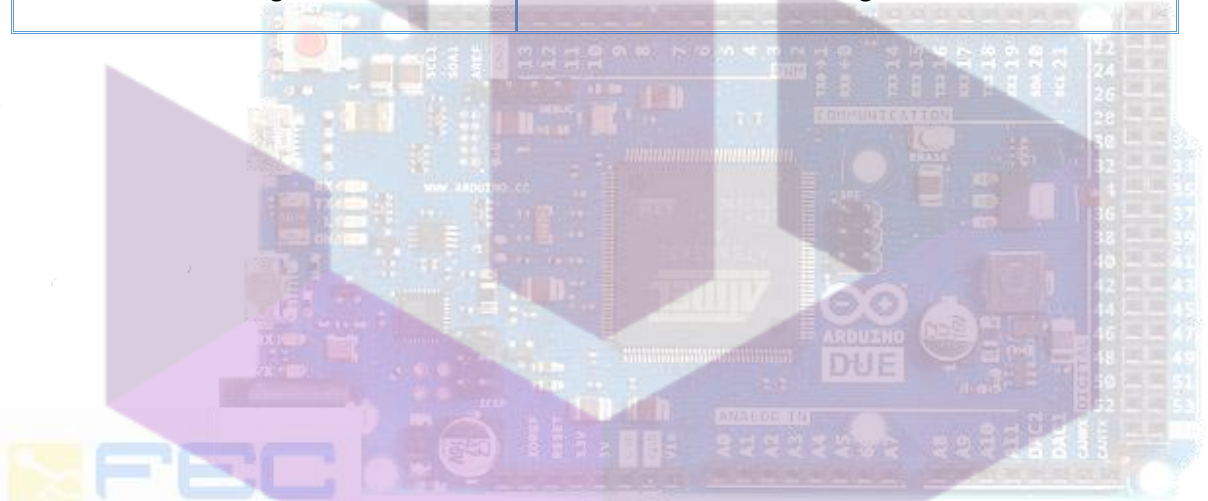

SKYTECH

تهیه و توزیع قطعات الکترونیک